

12 11 10 9 8 7 6 5 4 3 2 1

H G F E D C B A

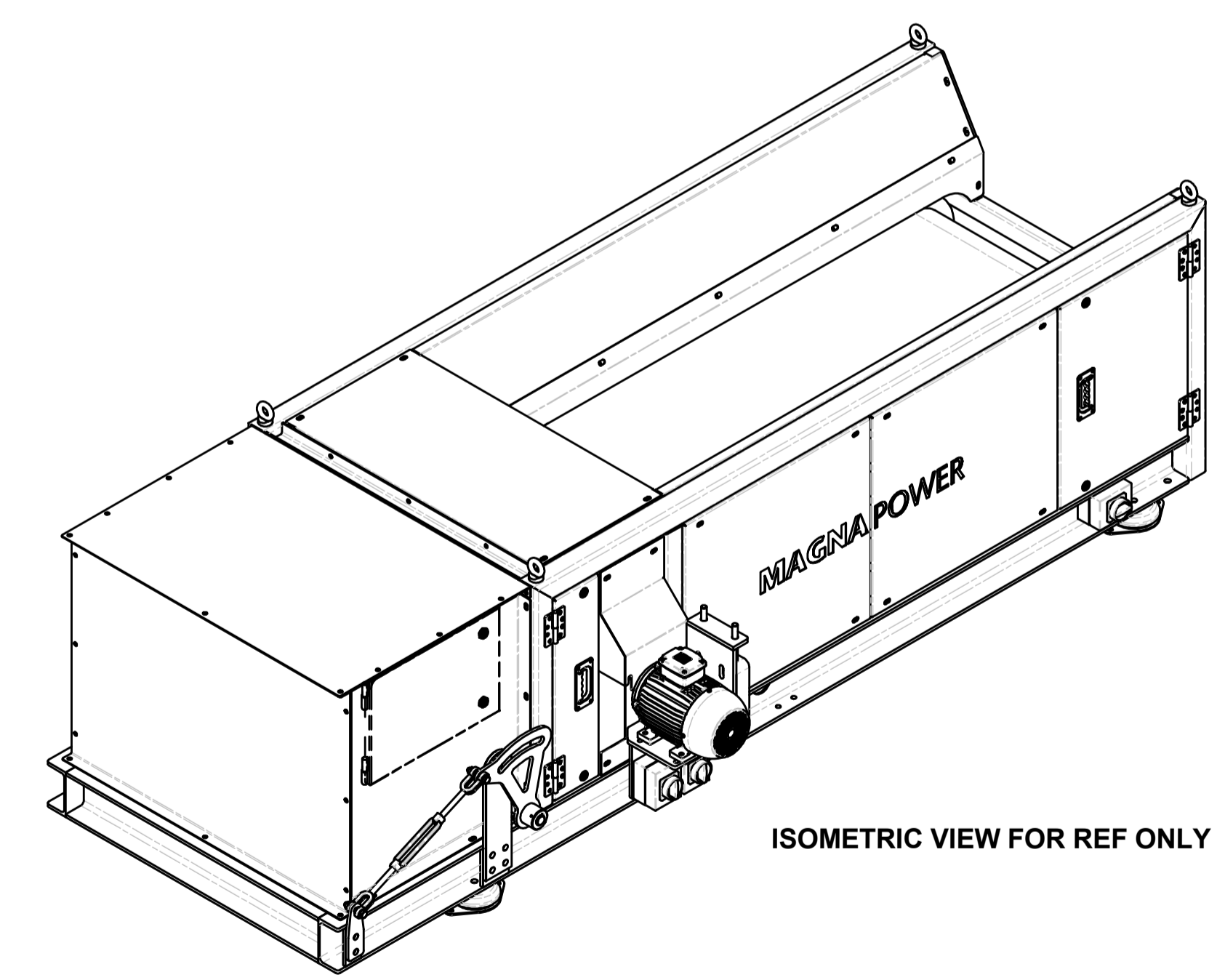
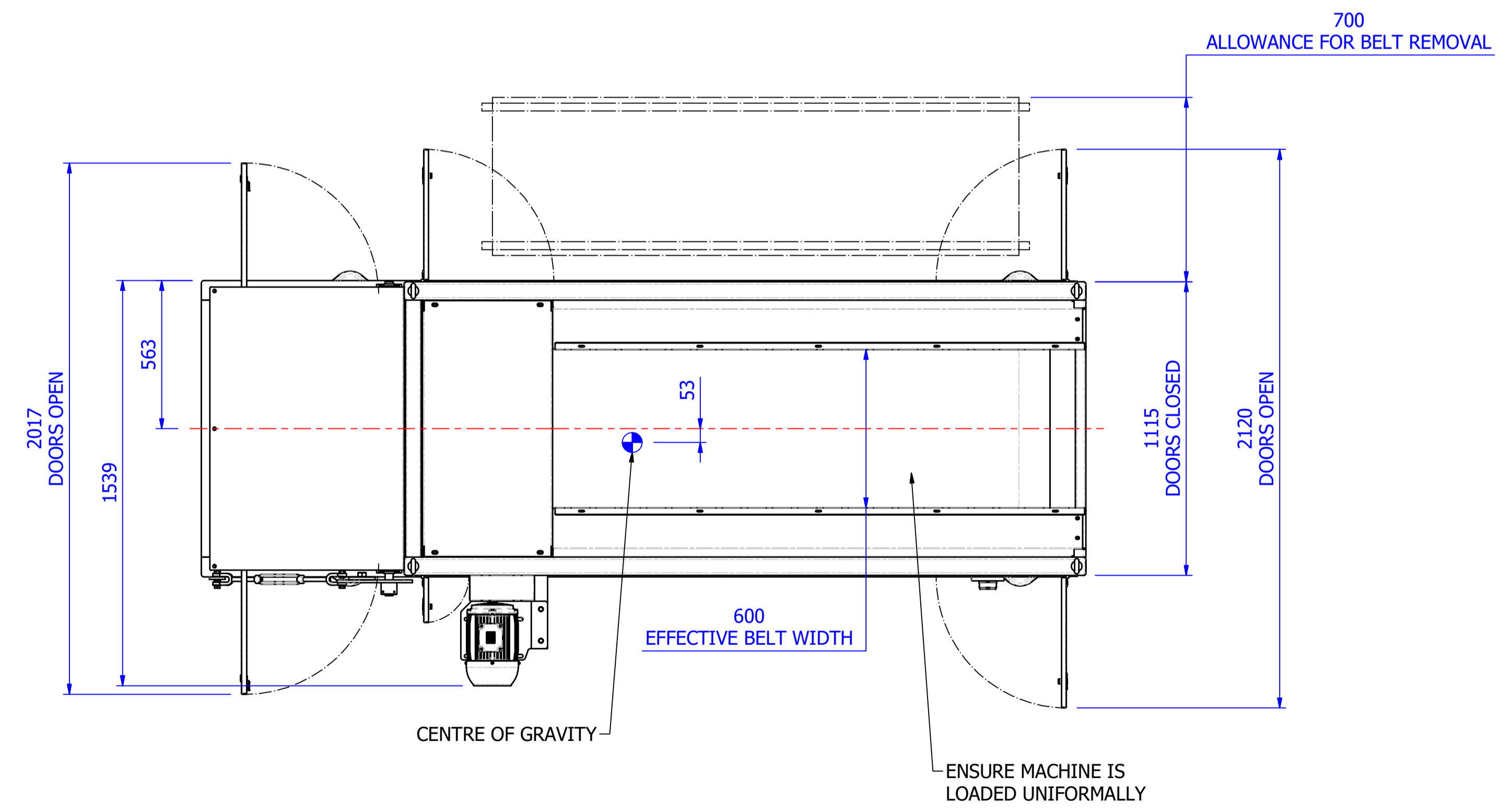
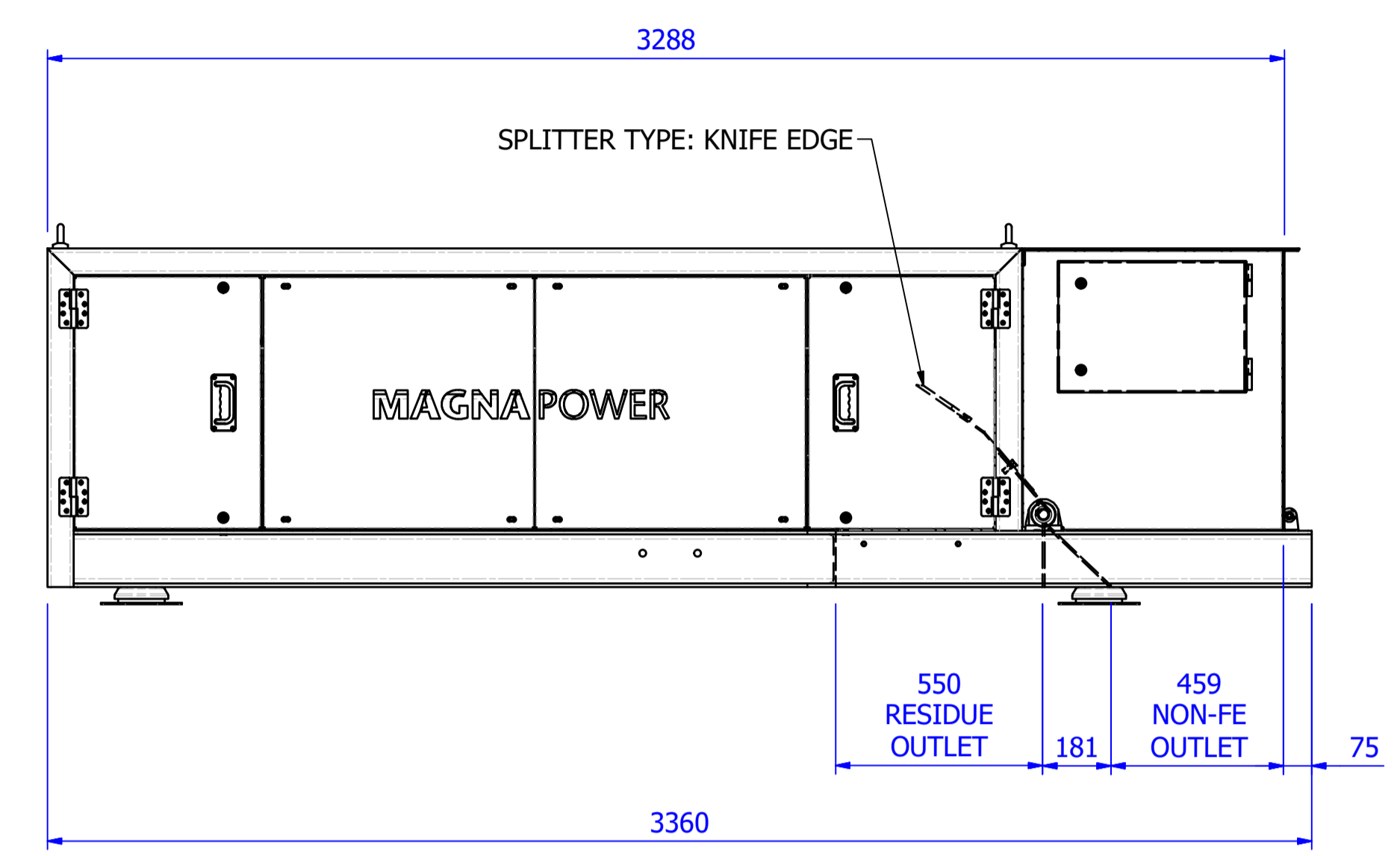
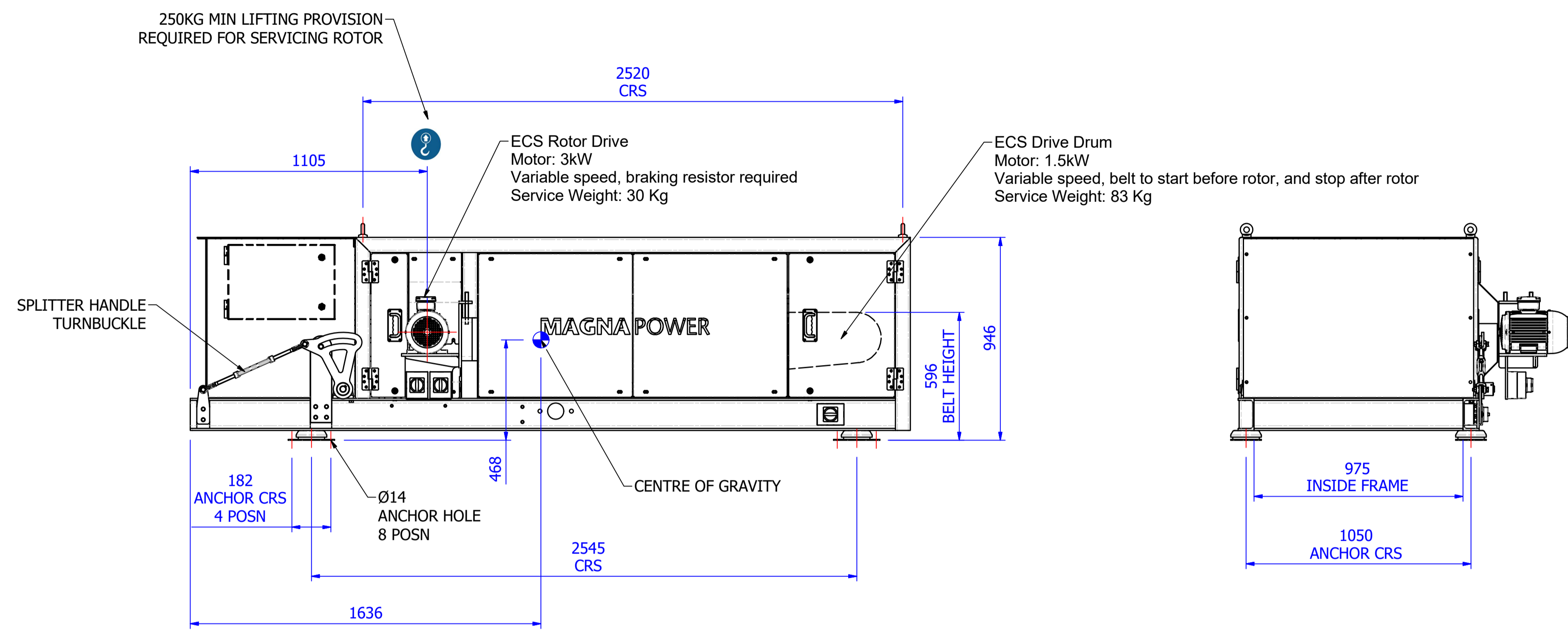

Please note:
1) Drawing for sales proposal use only.
2) Drawing may be subject to changes without notification.

DO NOT SCALE, if in doubt ask.

B	DWG SIMPLIFIED. ADDITIONAL FIXING INFORMATION ADDED. COG ADDED	20/09/2018	AP
A	DWG TITLE CORRECTED	29/08/18	AP
-	Drawing Issued	29/08/18	AP
REV	DESCRIPTION	DATE	APPROVED
REVISION HISTORY			

The information contained in this drawing is the confidential property of Magnapower Equipment Ltd and should not be passed on or related to a third party without the written consent of Magnapower Equipment Ltd

TOTAL MASS	1197.6 kg	CHECKED	
COLOUR	-	APPVD	
		DATE	
PROJECTION			

Magnapower Equipment Ltd
A1, Harris Business park
Hanbury Road
Worcestershire
B60 4FG
UK
Tel : 0044(0)1527 557092
Fax : 0044(0)1527 557019
Email : info@magnapower.co.uk

MAGNAPOWER	
TITLE	EC5600 BF.SH SF MkIII
DATE	29/08/2018
DRG. No	911.B.0015
DRAWN	AP
REV	B

12 11 10 9 8 7 6 5 4 3 2 1