

Technical Data

WL(K) 10 – WL(K) 20

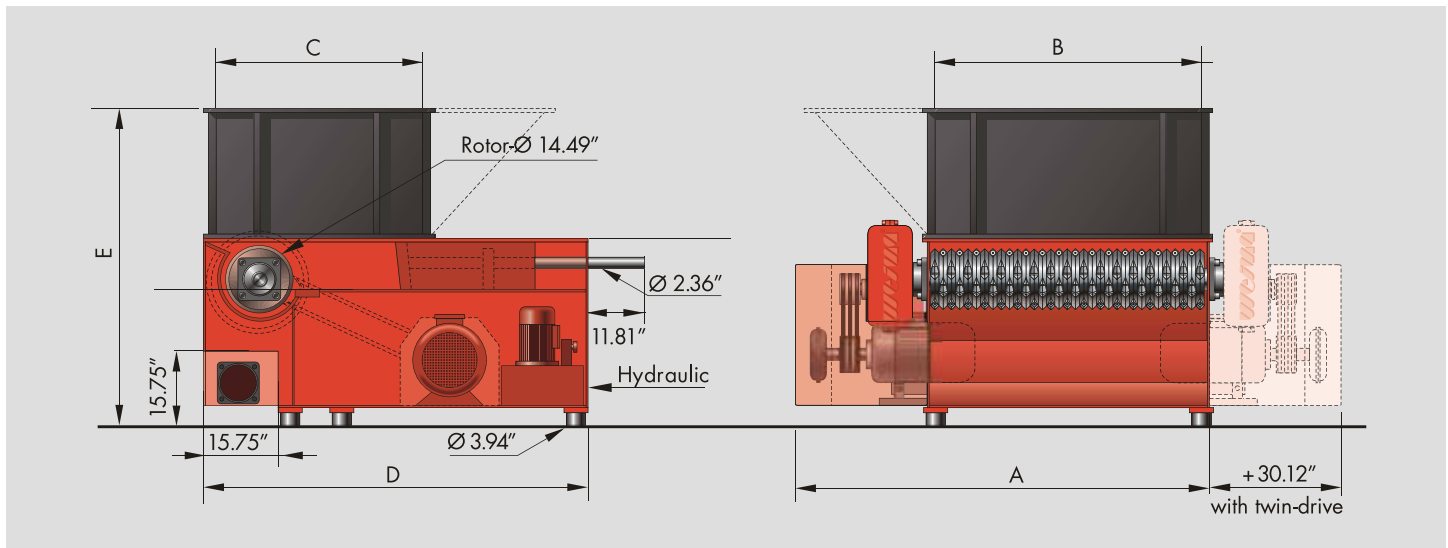

	WL(K) 10	WL(K) 12	WL(K) 13	WL(K) 14	WL(K) 15	WL(K) 18	WL(K) 20
Hopper opening (Inch):	39.4 x 47.2	47.2 x 47.2	51.2 x 47.2	59.1 x 47.2	59.1 x 59.1	70.9 x 59.1	78.7 x 59.1
(mm):	1,000 x 1,200	1,200 x 1,200	1,300 x 1,200	1,500 x 1,200	1,500 x 1,500	1,800 x 1,500	2,000 x 1,500
Hopper vol. (yd³/m³):	1.7/1.3	2.0/1.5	2.1/1.5	2.5/1.9	3.0/2.3	3.7/2.8	3.9/3.0
Throughput (kg/h):	The throughput rate depends on material composition and screen size						
Rotor diameter (In./mm):	14.5/368	14.5/368	14.5/368	14.5/368	14.5/368	14.5/368	14.5/368
Rotor speed (rpm):	60 – 120	60 – 120	60 – 120	60 – 120	60 – 120	60 – 120	60 – 120
Power (hp):	50/60	60/75	60/75	75/100/120	75/100/120	100/120/150	100/120/150
(kW):	37/45	45/55	45/55	55/75/90	55/75/90	55/75/90	75/90
Rotor knives:	52	64	68	82	82	100	112
Screen size (In./mm):	3/8 – 4" / 10 – 100mm (For all models)						
Connection-Ø (In./mm):	8/200	8/200	8/200	10/250	10/250	10/250	10/250
Weight approx. (lbs/kg):	7,700/3,500	8,800/4,000	9,900/4,500	11,000/5,000	12,300/5,600	16,000/7,300	17,900/8,100
Size A (Inch/mm):	70.9/1,800	78.7/2,000	82.7/2,100	90.6/2,300	90.6/2,300	102.4/2,600	118.1/3,000
Size B (Inch/mm):	39.4/1,000	47.2/1,200	51.2/1,300	59.1/1,500	59.1/1,500	70.9/1,800	78.7/2,000
Size C (Inch/mm):	47.2/1,200	47.2/1,200	47.2/1,200	47.2/1,200	59.1/1,500	59.1/1,500	59.1/1,500
Size D (Inch/mm):	82.7/2,100	82.7/2,100	82.7/2,100	82.7/2,100	106.3/2,700	106.3/2,700	106.3/2,700
Size E (Inch/mm):	67.7/1,720	67.7/1,720	67.7/1,720	67.7/1,720	67.7/1,900	74.8/1,900	74.8/1,900

Demonstrations and tests with your materials are possible in our facility by appointment.

WEIMA America, Inc.

3678 Centre Circle, Fort Mill, SC 29715

Phone: 803-802-7170 // Fax: 803-802-7098

www.weimaamerica.com // info@weimaamerica.com

With locations in:

Ilfeld, Germany // Ternberg, Austria // Northants, Great Britain // La Ferté s. Jouarre, France // Harjumaa, Estonia