

CAUTION ! Open magnetic field, risk assessment required when installed

Allow sufficient height for rotor removal 200 Kg min lifting provision required for servicing rotor

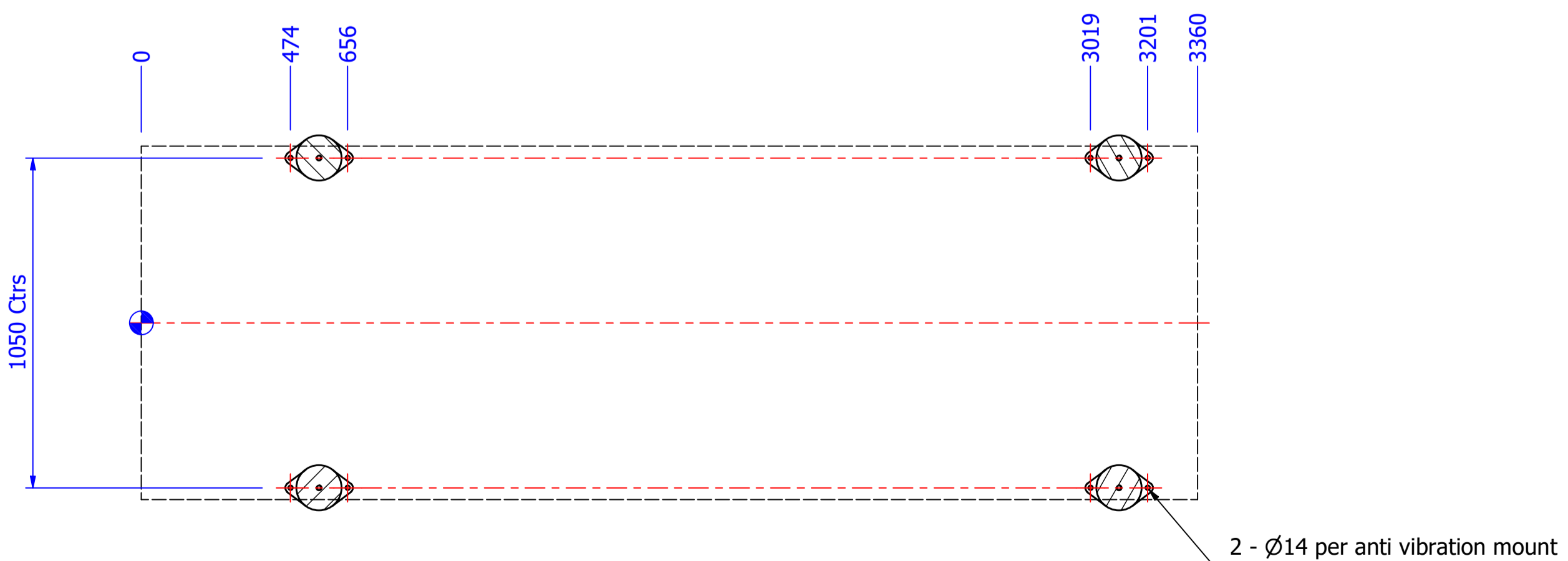

A-A (1 : 15)
Anchor Hole Positions

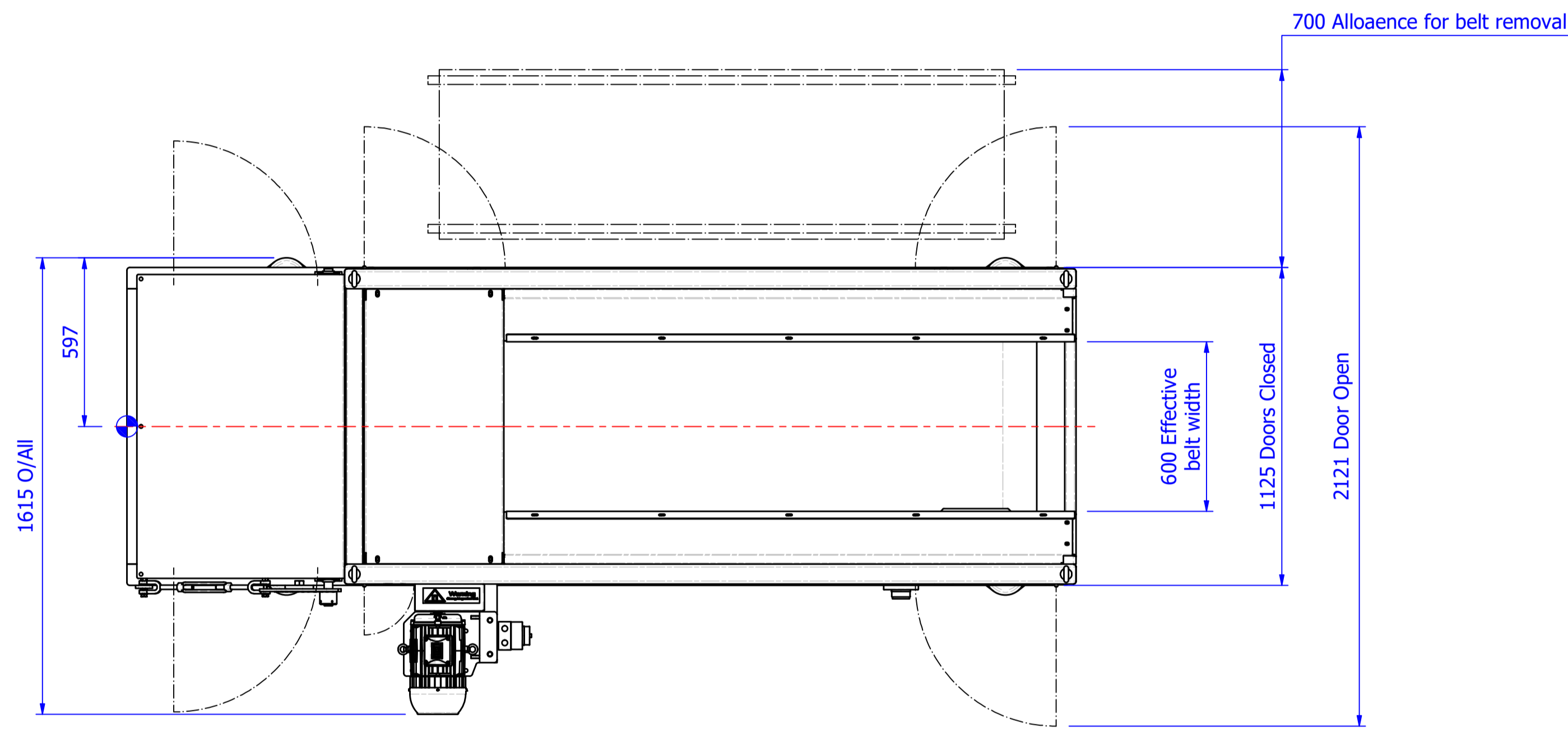
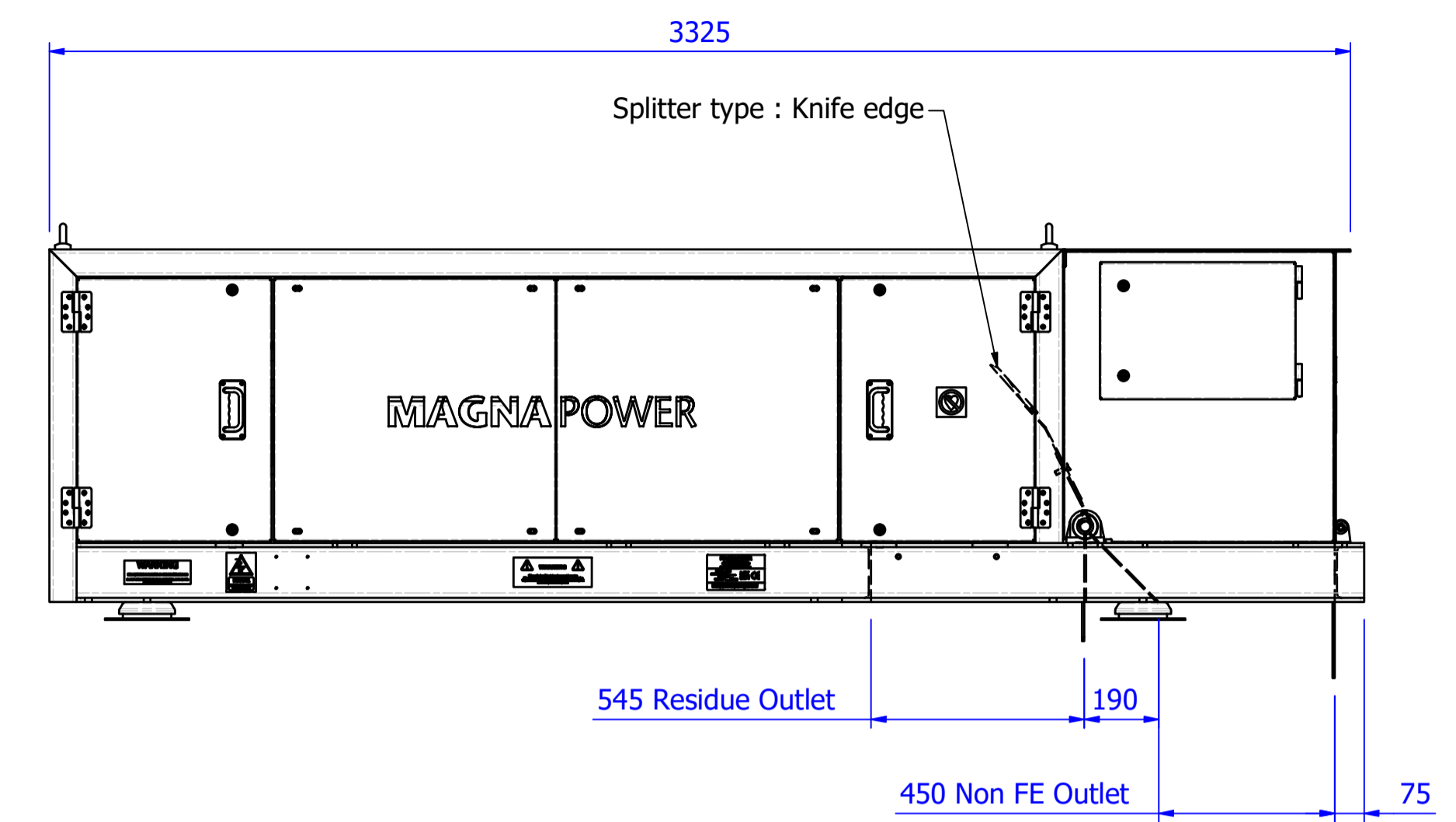
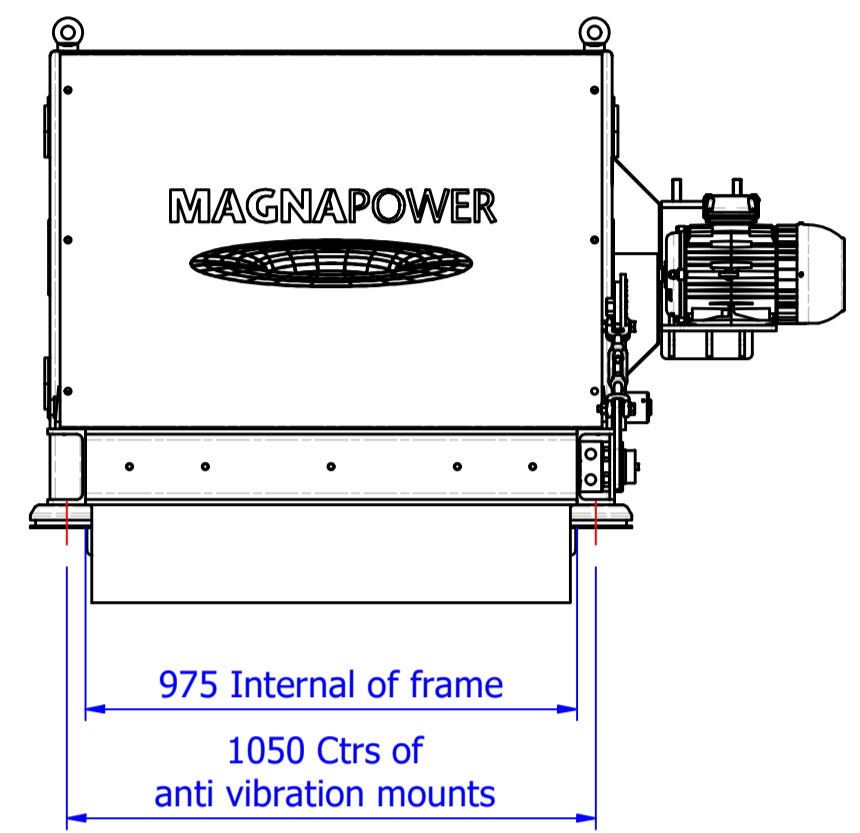
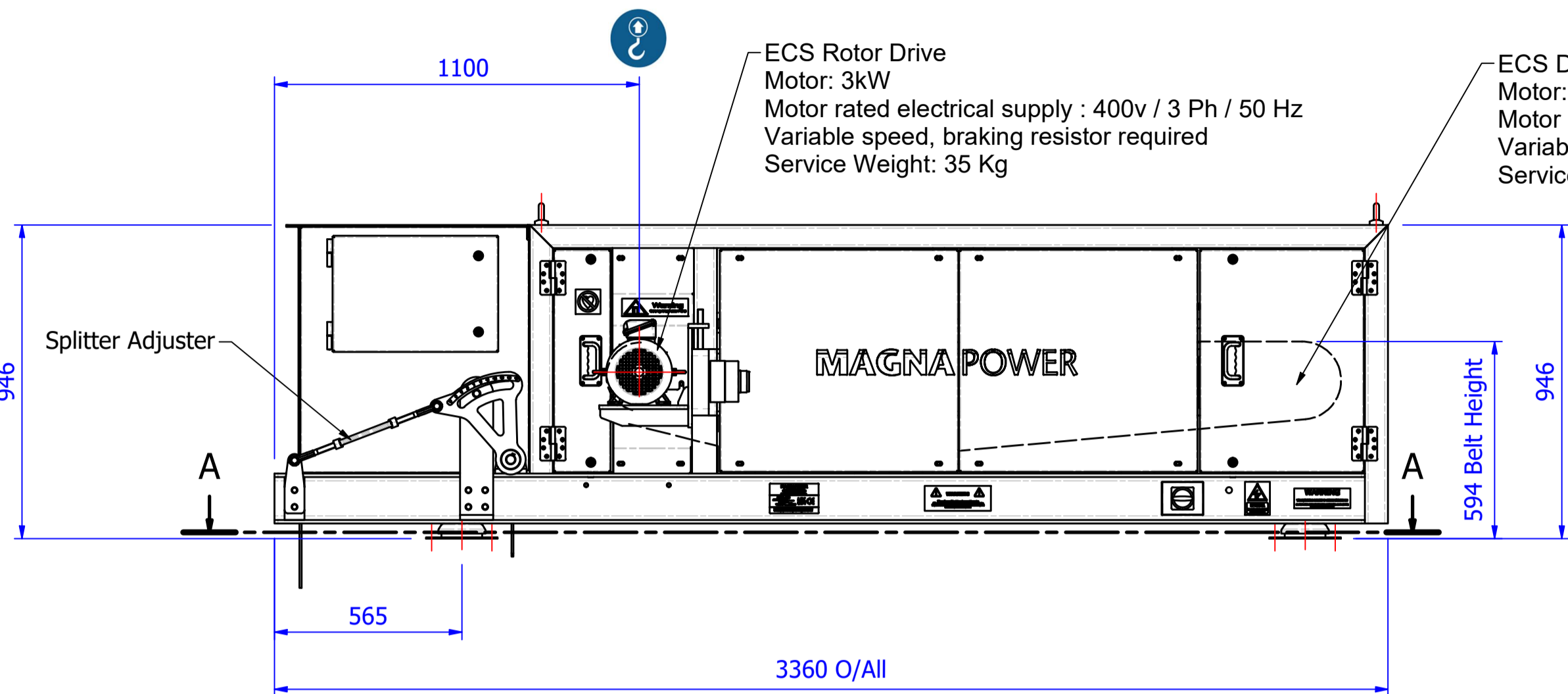
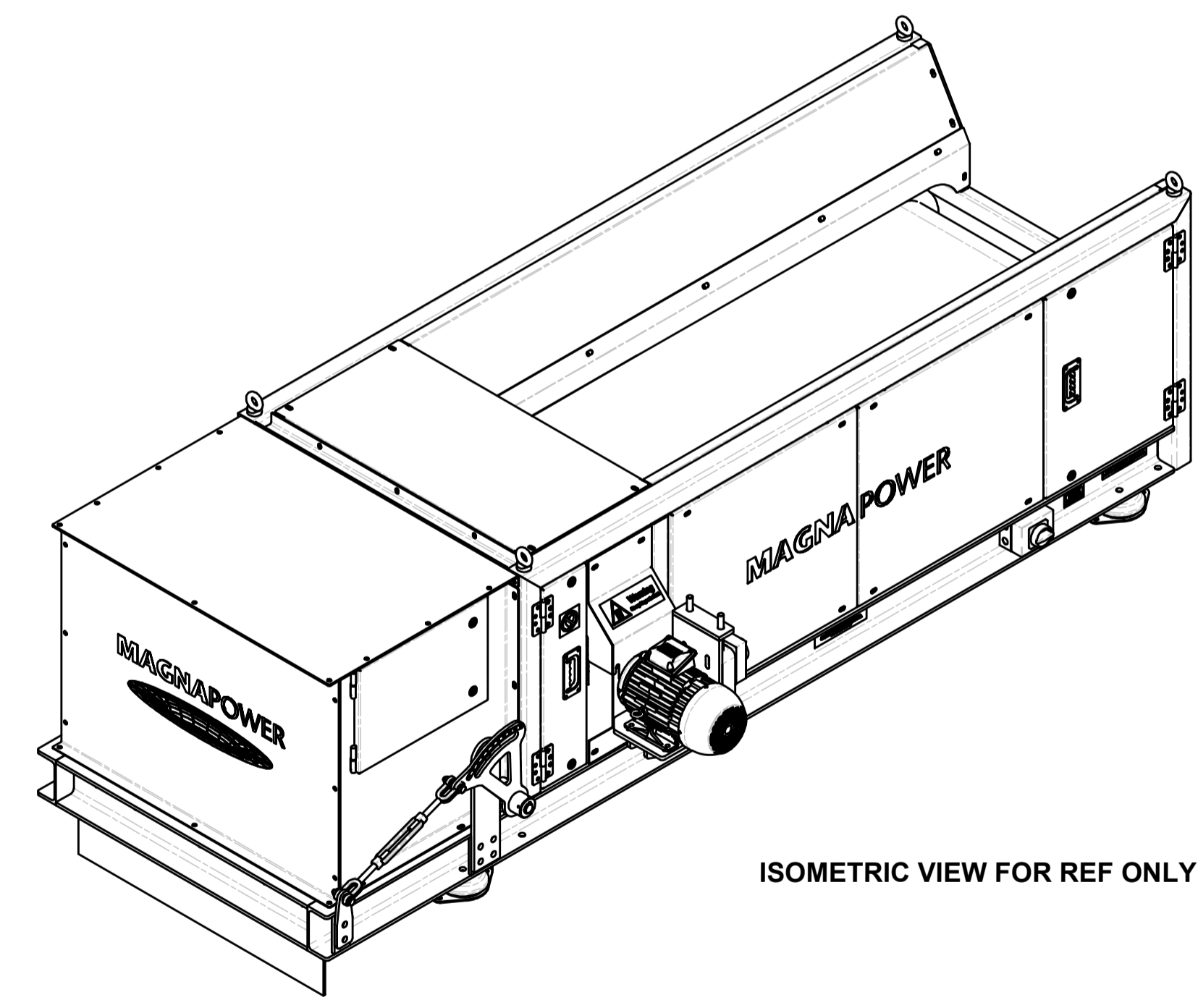

REV	DESCRIPTION	DATE	APPROVED
C	Drawing updated to latest standard	23/05/2022	MRD
B	DWG SIMPLIFIED. ADDITIONAL FIXING INFORMATION ADDED. COG ADDED	20/09/2018	AP
A	DWG TITLE CORRECTED	29/08/18	AP
-	Drawing Issued	29/08/18	AP

REVISION HISTORY

TOTAL MASS 1198 kg	CHECKED	Magnapower Equipment Ltd A1, Harris Business park Hanbury Road Worcestershire B60 4FG UK Tel : 0044(0)1527 557092 Fax : 0044(0)1527 557019 Email : info@magnapower.co.uk	MAGNAPOWER	
COLOUR -	APPVD		TITLE ECS 600 MkIII SF.BF.SH	DATE 29/08/2018
PROJECTION		DRG. No 911.B.3001		REV C

The information contained in this drawing is the confidential property of Magnapower Equipment Ltd and should not be passed on or related to a third party without the written consent of Magnapower Equipment Ltd

DO NOT SCALE, if in doubt ask.